

SINGLE DRUM ROLLER



SSR120C-8

STANDARD FEATURES

- ➔ Components from brands you trust like Cummins engines and Danfoss hydraulic motors for dependable performance
- ➔ Clear lines of sight, back up camera and air suspension seat offer operator comfort and job site safety
- ➔ Pad foot shell kit comes standard
- ➔ ROPS/FOPS Certified

145 hp
Net Power

25,814 lbs
Operating Weight

84"
Drum Width

DIMENSIONS

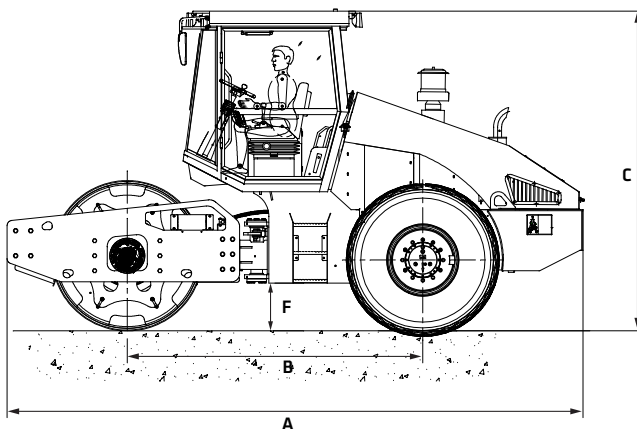
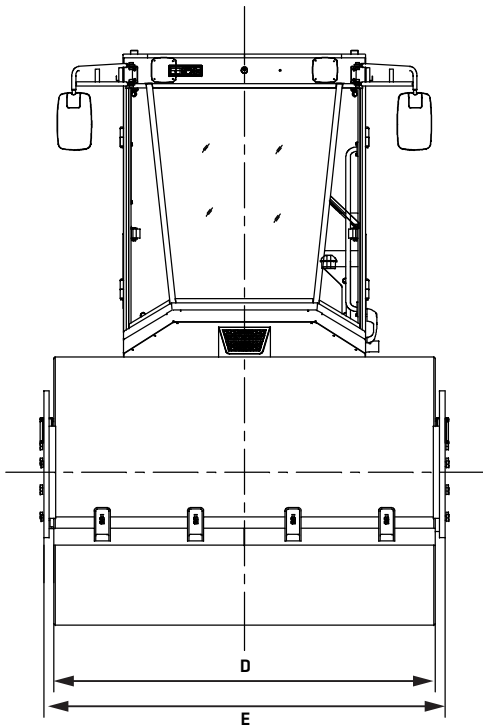

OVERALL DIMENSIONS

A	Overall Length	18' 10"	5 750 mm
B	Wheelbase	9' 8"	2 950 mm
C	Overall Height Smooth Drum	10' 6"	3 190 mm
C	Overall Height with Padfoot	11' 1"	3 390 mm
D	Drum Width	84"	2 130 mm
E	Overall Width	7' 4"	2 240 mm
F	Ground Clearance	18.9"	480 mm
	Drum Diameter	59.1"	1 500 mm
	Drum Shell Thickness	1.0"	25 mm
	Inside Turning Radius	12' 1"	3 670 mm
	Min. Outside Turning Radius	19' 1"	5 800 mm
	Curb Clearance	18.5"	470 mm



STANDARD FEATURES

s = standard

SSR120C-8		POWERTRAIN
s		QSB4.5 Cummins T4F
s		U.S. EPA Tier 4 Final / EU Stage V emissions standards
s		Three speed throttle switch
s		Dual-element dry air filter
s		Electronic engine control
s		High torque drum drive reducer
s		Fuel filter with water separator
s		Full-flow oil filter
s		Turbocharger with charge air cooler
s		500-hour engine oil change interval
s		Engine air precleaner
		VIBRATORY SYSTEM
s		Smooth drum
s		Dual amplitude, dual frequency
s		Dual adjustable steel smooth drum scrapers
s		Dual adjustable steel padfoot drum scrapers
s		Padfoot shell kit
		ELECTRICAL
s		24 volt electrical system
s		Ground level electrical disconnect (lockout tag out)
s		850 cold cranking amps battery capacity
s		Positive-terminal battery covers
s		Rearview camera
s		Back-up alarm
s		Emergency stop
s		Rotating beacon light
s		Halogen work lights
s		Indicator and hazard lights all LED



STANDARD FEATURES

s = standard

SSR120C-8	OPERATOR'S STATION
s	Open platform with handrails/guardrails
s	AM/FM radio with USB charging and Bluetooth® connectivity
s	Seatbelt
s	ROPS/FOPS cab
s	12 and 24v outlets 60 watt 5 amp
s	Deluxe heated air suspension cloth seat with adjustable armrests
s	Heavy-duty floor mat
s	Front windshield wiper with variable speeds
s	Illuminated gauge: diesel exhaust fluid, engine coolant, and fuel levels
s	Horn
s	Hour meter, electric
s	Internal rearview mirror
s	External rearview mirrors
s	Sunvisor
s	Adjustable, tilting steering wheel
s	Multifunction, color LCD monitor with: diagnostic capability / multiple-languages
s	Single lever control for travel and vibration
s	Engine check, engine coolant temperature indicator
s	Light with audible alarm, engine oil pressure indicator light with audible alarm, low-alternator charge indicator light, low-fuel indicator light, low DEF indication with audible alarm, fault code alert indicator, fuel rate display, wiper-mode indicator, work lights on indicator, and work-mode indicator
s	Air-suspension, heated seat
s	Hydraulic oil filter restriction indicator light
s	Cup holder
s	Interior lighting
s	Protection screens for cab front, rear, and side

PRODUCT SPECIFICATIONS ROLLER || SSR120C-8

MACHINE PARAMETERS

ENGINE

Engine Model	Cummins QSB4.5	
Emission	T4f	
Rated Gross Power	160 HP @ 2,200 RPM	162.2 MHP @ 36.67 Hz
Rated Net Power	145 HP @ 2,200 RPM	147.01 HP @ 36.67 Hz
Max Torque	460 lb-ft	624 N.m
Low Idle / High Idle	700 RPM / 2,386 RPM	11.67 Hz / 39.77 Hz
Displacement	1.2 gal	4.5 L
Stroke	4.89"	124 mm
Bore	4.21"	107 mm
# of Cylinders	4	
Max. Travel Speed	0~2.6/0~3.2 mph; 0~4.4/0~6.2 mph 0~4.1/0~5.2 km/h; 0~7.1/0~10 km/h	

WEIGHTS

Operating Weight	25,814 lbs	11 709 kg
Weight at Drum	14,350 lbs	6 509 kg
Weight at Axle	11,464 lbs	5 200 kg
Weight with Padfoot Kit	29,121 lbs	13 209 kg

ELECTRICAL

Battery	Model	6-QW-120MF
	Voltage	12V
	CCA	850 Amp
Alternator	Capacity	120 Ah
	Amp	70 Amp
Power Outlet	Voltage	24V
	Voltage	12V
	USB	12V

VIBRATORY SYSTEM

Frequency	32 / 36 Hz	
Amplitude	1.8 / 0.9	
Static Linear Load	188 lb/in	329 N/cm
Centrifugal Force	62,947 / 40,016 lb	280 / 178 kN

DRIVE SYSTEM

Tires	23.1-26-8PR	
Parking Brakes	3~3.5 Psi	2~2.4 MPa
Gradeability Smooth Drum	40%	
Gradeability Padfoot	30%	
Articulation	+/- 35°	
Oscillation Angle	+/- 8°	

SERVICEABILITY AND FILL CAPACITIES

Fuel Tank	52.8 gal	200.0 L
DEF Tank	5.0 gal	19.0 L
Cooling System	10.5 gal	39.7 L
Hydraulic Tank	31.7 gal	120.0 L
Engine Oil (with filter)	5.6 gal	21.0 L
Vibratory Drum	2.6 gal	10.0 L
Drum Final Drive (Reducer)	1.6 gal	6.0 L
Axle Final Drives	0.5 gal	1.8 L
Rear Axle	5.3 gal	20.0 L
Travel Bearing (Grease)	0.9 gal	3.4 L

SOUND LEVEL

Operator's Ear in the Cab	82 db
External	108 db

PADFOOT SHELL KIT

# of Pads	108	
Pad Height	3.9 in	100 mm
Pad Face Area	11.5 in ²	74 cm ²

In the interest of continual equipment development, SANY America Inc. reserves the right to change these specifications at any time without prior notification.

SANY

SANY America Inc.
318 SANY Way
Peachtree City, Georgia 30269
470.552.SANY

©2023 SANY America Inc. HEXPS23SSR120C8001



[sanyamerica.com](https://www.sanyamerica.com)



*Warranty applies to 2023 Crane, Telehandler, Grader and Roller models only.